

salisbury glass centre

L I M I T E D

WINDOWS, DOORS & CONSERVATORIES

Quality workmanship since 1952

OPERATION & MAINTENANCE MANUAL

Dear Customer

Congratulations on the purchase of your new windows & doors, we trust you will enjoy trouble free usage for many years to come.

However, as with any equipment, to obtain complete satisfaction it is advisable to carry out the simplest of regular maintenance.

This booklet contains a variety of useful tips and information to help you get the best from your investment.

As our policy is one of continuous improvement in products, methods and materials, changes in specification may be made from time to time without prior notice.

MAINTENANCE

Glass Cleaning

- Float Glass, used in most double glazed units, is easily scratched and it is therefore recommended that hand jewellery is removed prior to cleaning.
- Any proprietary household cleaner may be used with a soft cloth and it is recommended that heavy external grime be initially removed with a solution of soap and water.
- Laminated glass, or glass containing Georgian bars, is cleaned in exactly the same manner.
-

It is imperative that glass surfaces are cleaned on a regular basis to stop water staining. Water carrying atmospheric contamination will leave permanent marks on the glass surfaces if left un-cleaned for long periods.

All glass surfaces should be cleaned at least once every 3 months.

Leaded Glass Cleaning

- In this type of double glazing, lead strips are bonded to the inside of the unit in diamond or square patterns.
- Take care when cleaning leaded lights as excessive pressure might dislodge the lead from the glass surface.
- The use of warm soapy water and a soft cloth, moderately applied will prove an adequate cleaning method.

Note:- External lead will oxidise. This is a natural phenomenon and cannot be avoided.

Scratched Glass

- If scratches occur, most can be removed with jewellers rouge, or an equivalent rubbing compound.

(See pages 8 & 9 for further information on glazing.)

PVC-U FRAME CLEANING

Avoid all solvent based or abrasive cleaners

- Wash frames with a soap and water solution every four months to remove any grime and atmospheric deposits.
- If required, clean with a non-abrasive proprietary cleaner to remove any stubborn blemishes.
- Take care not to disturb sealants.

Conservatory & Porch Roof Cleaning

Avoid all solvent based or abrasive cleaners.

- Polycarbonate roofing panels fitted to these structures must be cleaned in a similar manner to PVC-U frames.
- Clear gutters of leaves and debris as required to avoid overflow of rain water and ensure unobstructed drainage.
- Wash roof panels with soap and water solution every four months to remove grime and atmospheric deposits.
- **Do not use any solvent or silicone based cleaners on solar control or self cleaning glass roofs.**
- **It is important to clean out all boxed gutters on a regular basis especially in the autumn time when there is heavy leaf fall.**

Do not walk on conservatory roofs without appropriate supports or scaffolding.

DRAINAGE

- Your double glazed products are designed with an in-built drainage system, comprising slots within the thresholds that allow any water ingress to flow to the outside. To ensure an efficient system these slots must remain unblocked.
- Periodically, remove dirt, clear drain holes and check drainage operation by flushing through with water.

WEATHERSEALS

- During cleaning and general maintenance ensure that the weather seals fitted to your products do not become dislodged from their grooves. Should this occur, slide back into position immediately to avoid damage when the product is closed.
- If the weather seals are broken or damaged and draughts are felt around the product, ensure prompt replacement by contacting your installer.

LUBRICATION

For lubrication of hardware etc. use light machine oil (e.g. 3-in 1-or spray grease) lubricant for moving parts and petroleum jelly where indicated in the product specific lubrication instruction.

MASTIC SEAL

Please note that some discoloration of the mastic seal is a natural occurrence and cannot be avoided.



BRASSWORK

When installed, brass work is fully protected with lacquer. In time and through normal wear and tear, this lacquer may peel or become tarnished.

Note:- We cannot accept responsibility for this natural occurrence.

To refurbish your brass work carry out the following procedure:-

- You are advised to protect the PVC-U surfaces from chemicals etc. by masking off an area around each piece of brass work.
- Remove old lacquer with nail polish remover/paint stripper.
- Clean and polish with a suitable proprietary brass polish.
- Carefully re-lacquer with a good quality product.

CONDENSATION

Water vapour is continually present in the atmosphere.

In the home, this natural water content is increased by normal day to day living. For example, activity that generates steam such as cooking, bathing, laundering, boiling a kettle or even breathing.

The water vapour remains undetectable while floating in warm air, but upon contact with cold surfaces: windows, mirrors, tiles etc., condensation occurs and the vapour turns to water droplets.

Traditional house construction allowed the escape of this water vapour through natural ventilation - open flues of coal fires, air bricks and ill fitting windows and doors.

The drive to conserve energy and reduce heating costs has led to the sealing of homes, resulting in trapped water vapour and increased problems of condensation.

CONDENSATION (CONTINUED)

VENTILATION

Provide natural ventilation whenever possible by:-

- Opening a window
- Fitting a ventilator/extraction unit in the kitchen and bathroom.
- Fitting wall vents to provide air flow.

N.B. Security should be borne in mind when leaving open an easily accessible window.

HEATING

- Maintain some permanent heat in the house during cold weather. Marginally increase the temperature in areas where condensation is a particular problem.
- If possible, fit radiators under windows to maintain the temperature of the inside pane of your double glazing.

CIRCULATION

Water vapour will easily drift on convection currents far from where originated.

- Keep internal doors to kitchen and bathroom areas closed and draught sealed, where possible, to prevent the excessively moist air in these rooms being transferred to other areas of the house.
- Bedroom windows should have a night ventilation facility to provide air movement. Ideally, if bedroom doors are closed, a ventilation grille should be installed in or above the door also.
- To ensure air flow in the vicinity of windows, curtains should be a minimum of 150mm (6") away from the window, with suitable gaps, top and bottom, to allow circulation.
- A good tip is not to pull curtains totally together allowing a 200mm gap or leave any unused room's curtains undrawn.

Page 7

SECURITY

PREVENTION IS BETTER THAN CURE

Your double glazed windows and doors have been specifically designed to include a variety of security features to protect your home and family against intrusion.

We recommend a number of sensible precautions which should be taken to gain full advantage of the security features available with your double glazing:-

- Never leave a window open when your home is unattended.
- For added protection, lock all windows in the closed position and remove the keys.
- To provide adequate means of escape in the event of any emergency, we recommend that keys to all windows are located adjacent to the window, but out of external view.
- When leaving the house unattended or at night, ensure door handles are fully lifted and that the keys are turned to throw and lock all deadbolts/hook bolts for full security.

PAGE 8

GLAZING

GLASS DEFECTS

All double glazed units are susceptible to a degree of surface damage during the manufacturing process. Certain imperfections in the glass cannot be avoided, even in the most carefully controlled production environment.

Such blemishes and imperfections are inherent in all double glazing and therefore beyond our control, but are considered acceptable by the most rigorous industry standards.

We wish to draw your attention to the following extract from an industry accepted standard, relating to glass generally.

1. Transparent Glass, used in the manufacture of double glazed units is identical to that used in traditional single glazing and will therefore have a similar level of quality.
2. Both panes of the double glazed unit shall be viewed from the room side, standing at a distance of two meters (6.5') in natural daylight and not in direct sunlight. The area to be viewed is the normal vision area, with the exception of a 50mm (2") wide band around the perimeter of the unit.
3. Flat Transparent Glass shall be deemed acceptable if the following phenomena are neither obtrusive or bunched:-
 - a. Totally enclosed seeds.
 - b. Bubbles or blisters.
 - c. Hairlines or blobs.
 - d. Fine scratches, not more than 25mm (1") long.
 - e. Minute embedded particles.
4. Obtrusiveness of blemishes shall be judged by looking through the glass and not at it, under normal lighting conditions as described in point 2.

Extracted from the Glass & Glazing Federation Standards.

GLASS DEFECTS (CONTINUED)

Salisbury Glass Centre Ltd uses only the highest quality float glass available, whether laminated, toughened or annealed, which conforms to the requirements of BS6262.

Double glazed units produced to BS EN 1279, conform to the highest manufacturing standards and most uncompromising quality control and inspection routines.

Double glazed units manufactured using insulating coatings can reduce the visual quality of the unit resulting in a “haze” appearance, especially when viewed with the sun in a lower position. This is not a glass fault and cannot be avoided when using this type of glass.

When glass goes through the toughening process it can also affect the visual appearance, resulting in “roller waves” usually seen when viewing the glass from outside at an angle to the light reflection. This is an inherent part of the process itself and cannot be avoided.

PATTERNED GLASS

This glass originates in very large sheets and due to spacing repetition, centralization of any design in a specific window, cannot be guaranteed.

OPEN-OUT WINDOWS

This window may be opened outwards to any angle, with its friction hinges holding it in any desired position. Locking is achieved by the mushroom cams and shoot bolts of the locking mechanism, fitted to the opening edge of the window, engaging into slotted and recessed keeps fitted to the bottom and sides of the outer frame.

These slotted keeps have secondary slots incorporated within them, which when engaged provide a 'Night Vent' position. This allows the windows to be only slightly open, while providing ventilation.

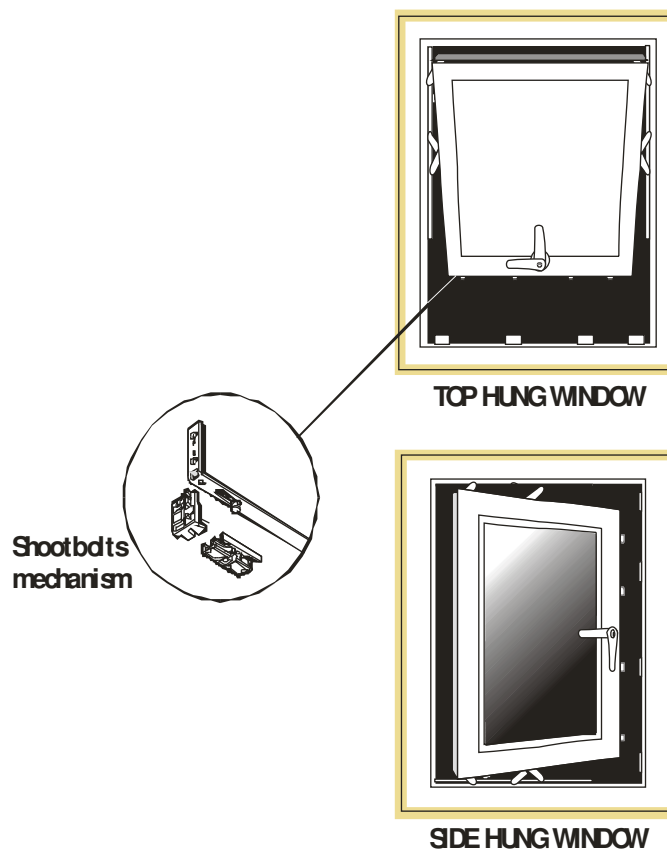

NOTE:- Accessible windows should not be kept in the night vent position when the house is unoccupied.

OPERATING INSTRUCTIONS

- If fitted, turn key or depress button to unlock the locking handle.
- Rotate the handle through 90° to disengage locking mechanism and open by pushing outwards.



FRICITION HINGES

To attain optimum performance, the scissor mechanism of the friction hinges will require periodic lubrication, normally 2 x per year. The pivots, sliding shoe and track should be kept free of dirt and debris and lightly oiled, including the stay arms etc.

Areas of high friction or wear should have petroleum jelly applied.



PAGE 12

LUBRICATION

- As required, usually two times per year.

- Oil all pivot points (one drop per pivot is sufficient) and wipe away excess, wipe over the exposed metal work with a oily cloth.
-

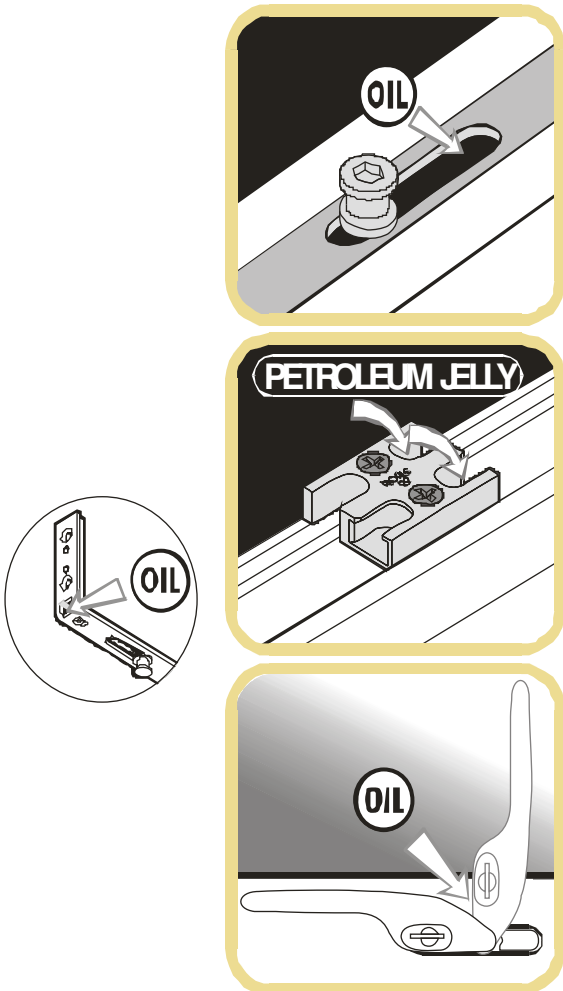

PAGE 12

SHOOTBOLT

Locking Mechanism

- Lubrication - as required
- Keep sliding mechanism free of dirt and lubricate each slot with light machine oil or spray grease.
- Keep shoot bolt free of dirt and lubricate slot with light machine oil.
- All exposed metal work should be cleaned with an oily cloth.

KEEPS

- Lubricate the slots of the keeps with petroleum jelly as required.

HANDLES

(Espagnolette Locking)

- Clean and lightly oil moving parts.

TILT BEFORE TURN WINDOW

These versatile inward opening windows are capable of two modes of operation.

- Tilt mode for ventilation.
- Turn mode for cleaning and emergency exits.

The term 'Tilt before Turn' (TBT) refers to the sequence of operation of the window which is designed for safety, to initially select the 'Tilt' mode, followed by the 'Turn' mode.

Locking is achieved by a series of cams or espagnolettes, located on a sliding mechanism around the edge of the window. When shut and the handle 'closed' position is selected, the cams engage into keeps fitted around the outer frame, providing a secure locking system and excellent weather sealing.

Note:- These windows can also be supplied in the Turn before Tilt mode, whereby the sequence of operation is reversed. If you are in any doubt as to the sequence of operation please contact your installer.

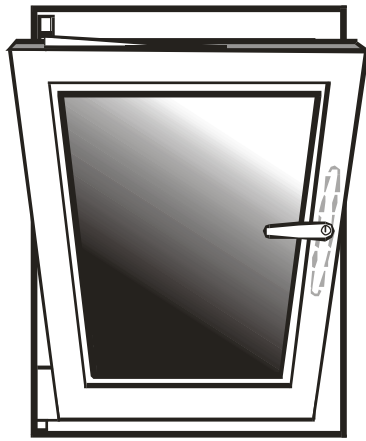

TILT MODE



TURN MODE

OPERATING INSTRUCTIONS

To operate the window, the handle is placed in one of three positions, 'Closed', 'Tilt' or 'Turn'.

The operation sequence commences with the window in the 'Closed' position (Handle vertically downwards).

Note:- The window must always be fully shut before changing the handle position.

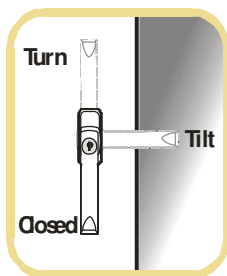

- If fitted, turn key to unlock.
- To select 'Tilt', rotate the handle through 90° from vertically downwards to horizontal and pull the window inwards. The bottom remains hinged to the frame, while the top tilts inwards to allow ventilation.

Page 14

- To select 'Turn' from the 'Tilt' mode, close the window and rotate the handle from its horizontal position to vertically upwards and pull the window inwards. The side remains hinged to the frame, while the window may be opened inwards to any desired position.
- To select 'Turn' from the 'Closed' position, rotate the handle through 180o from vertically downwards to vertically upwards and pull the window inwards.

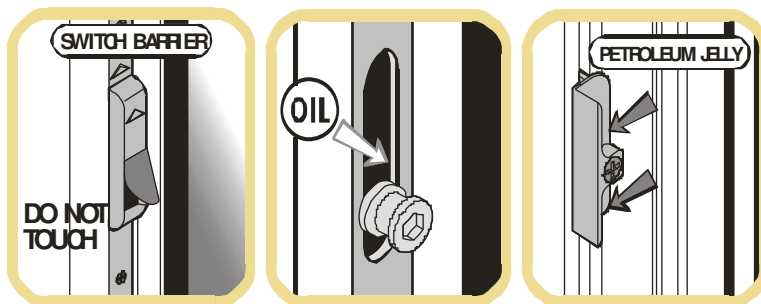

The switch barrier projecting from the locking mechanism, adjacent to the handle, is a safety device which ensures that only one mode, 'Tilt' or 'Turn', can be selected at any one time by securing the handle into the selected mode, while the window is open. Avoid pressing the switch barrier as this action releases the handle and could allow it to be inadvertently rotated to the alternative mode, resulting in the window disengaging from its gear.

Always firmly close the window before changing the handle position.

TBT LOCKING MECHANISM

Keep sliding mechanism free of dirt and lubricate each slot with light machine oil as required and clean all exposed metal work with an oily cloth.

KEEPS

Lubricate the faces of the keeps with petroleum jelly as required.

HANDLES Clean and lightly oil moving parts.

FULLY REVERSIBLE WINDOW

The window rotates through 180o to allow internal cleaning of the external pane.

Safety catches limit the initial opening and operate again at full rotation. Locking is achieved by multi-tongue bolt espagnolette mechanism.

Lock keeps also allow a 'Night Vent' position providing a more fixed form of ventilation.

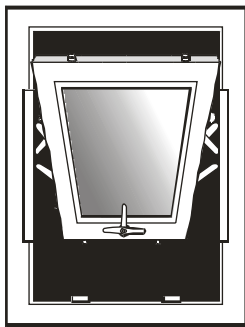

OPERATING INSTRUCTIONS

To open for night vent

Turn key to unlock.

Rotate handle 90o to vertical, open slightly and close handle to engage night vent slots.

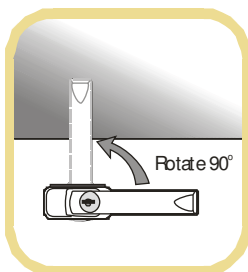

Page 16

To Open for Restricted Ventilation (Spilka Gearing Only)

- Operate handle and push outward until catch engages.

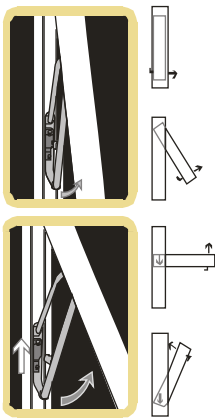

To Rotate for Cleaning

- Disengage catch (by pushing catch upwards) and push outwards while pulling top down and rotate window until catch re-engages

To Rotate to Close

- Disengage catches and push top outwards while pulling bottom up to return to closed position. Pull inwards and operate handle to fully close. Turn key to lock.

To open for Restricted Ventilation (PN/Mila Gearing Only)

- Operate handle and push outward until catch engages.

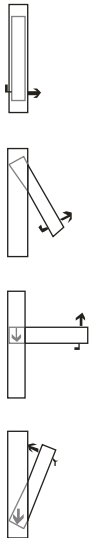

To Rotate for Cleaning

- Disengage catch (by pushing the button located on the jamb marked "PRESS" until it passes the two stops in the channel) and push outwards while pulling top down and rotate window until catch re-engages.

To Rotate to Close

- Disengage catches (by pushing the button located on the jamb marked "PRESS") and push top outwards while pulling bottom up to return to closed position. Pull inwards and operate handle to fully close. Turn key to lock.

Lubrication

- The lubricate around the pivot points
- Lightly grease the sliding tracks and any restrictors.
- Lubricate the keeps with petroleum jelly.
- Lightly oil external moving parts.
- **Lubrication should be carried out twice per year, more regularly in exposed areas.**

RESIDENTIAL DOOR

Door may be fitted with lever/pad handles that limit outside opening by use of a key, or lever/lever handles allowing external opening by handle movement.

High security locking systems can comprise of either triple deadbolts with latch lock or twin hook bolt / single deadbolt combination with latch lock, in addition up to 4 rollers may also be present. All locking points engage in keeps fitted to the frame jamb. The top and bottom deadbolts/hook bolts and rollers (if fitted) are engaged by lifting the handle.

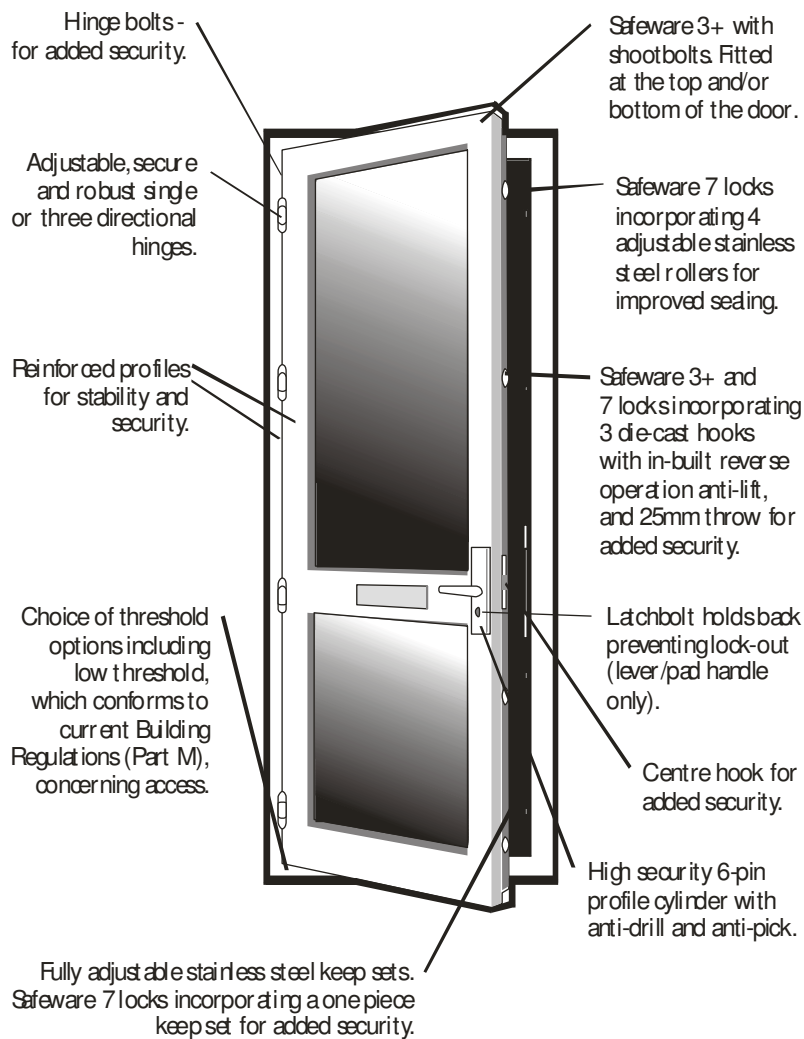

Page 19

To Lock

1. Close the door until the latch lock engages.
2. Lift the handle or pad to engage the top and bottom deadbolts/hook bolts/ rollers.
3. Insert key and turn to engage centre deadbolt and fully lock.

If the key will not turn lift handle or pad to maximum position and then turn key.

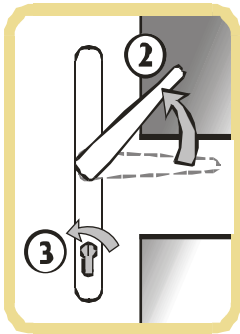

To Unlock

1. Insert key and turn to unlock.
2. Press handle or pad down to disengage top and bottom deadbolts/hook bolts/rollers.
3. With lever handle, door will open.
4. With pad handle, continue to turn key to open.

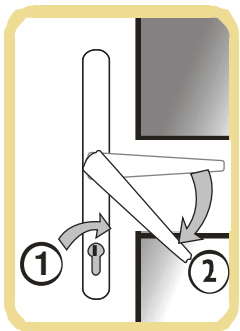

Lubrication - As Required

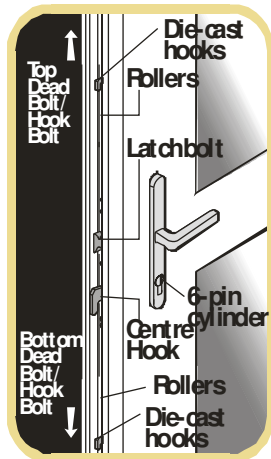

Locking Mechanism

- With the door open, lubricate the dead-bolts/hook bolts/rollers and latch lock with light machine oil.

Hinges

- Clean and lightly oil hinge pins. If hinges are external (Open-out door) lubricate every six months.

Handles

- Clean and lightly oil external moving parts.

Lock Cylinder

Only Lubricate (fine oil) if key entry is difficult.

Letter Box

. Wipe over with a damp cloth and lubricate on the pivot points when necessary.

Please note the guarantee does not apply to surface finishes or faults caused by willful or neglectful damage or excessive wear & tear.

DOUBLE DOOR

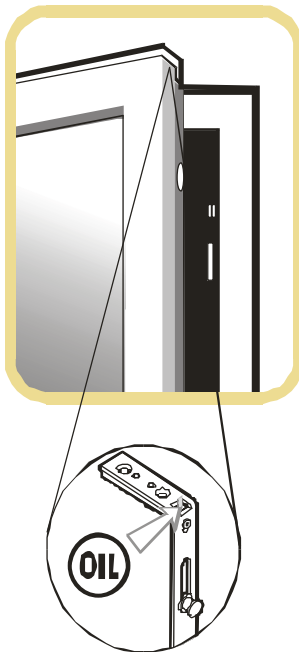

- **Full Slave Locking**

Handle operated shoot bolts are fitted to each side of double (French) doors. Lubricate as required, lightly oiling external moving parts as indicated in the diagram on the previous page and on the right.

Hand operated flush bolts are fitted to the top and bottom of the slave door.

Hand operated finger bolts are fitted to the top and bottom of the slave door.

Lubrication - As Required usually twice per year more often in exposed areas.

Lightly oil external moving parts and all exposed metalwork.

TILT & SLIDE DOOR

This versatile inward opening door can be 'Closed', placed in the 'Tilt' mode for ventilation, or in the 'slide' mode to clear the doorway for access.

Locking is achieved by a series of cams, or espagnolettes located on a sliding mechanism around the edge of the door. When shut and the handle in the 'Closed' position, the cams engage into the keeps fitted around the outer frame, providing a secure locking system and excellent weather sealing.

In addition the 'Tilt' mode may be selected and locked to provide secure ventilation.

To operate, the handle is placed in one of three positions, 'Closed', 'Tilt' or 'Slide'.

Closed (locked) to 'Tilt' (locked)

Insert key and rotate to unlock. Move handle 90o to horizontal (top of door will tilt inwards). Rotate key to lock and remove.

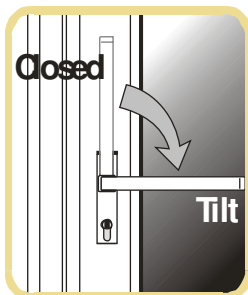

Page 23

Closed (locked) to 'Slide' mode

Insert key and rotate to unlock. Move handle 90o to horizontal and press spring loaded handle down and release. (Door will eject from doorway.)

Slide door on track to clear access.



Tilt (locked) to 'Slide' mode

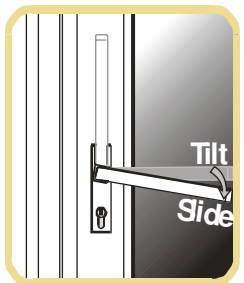

- Insert key and rotate to unlock.
- Press spring loaded horizontal handle down and release (Bottom of door will eject from doorway).
- Slide door on track to clear for access.

Lubrication - As required, usually twice per year & more often in exposed areas.

Runner Arms and Stay Arms

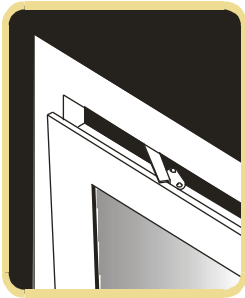

- With door in slide mode, lubricate the moving parts and track of the bottom & top runner arms with light machine oil.
- Ensure mechanism is free of grit and wiped over with an oily cloth.

Locking Mechanism

Lightly oil locking cam slots.

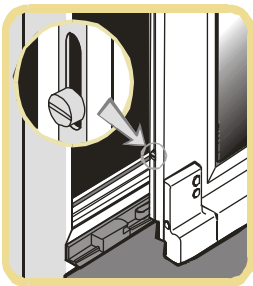

Bottom track

Lightly lubricate the running track to stop any corrosion.

Ensure track is permanently clear of dirt and debris and wipe over all exposed metalwork with an oily cloth.

Handles

Clean and lightly oil external moving parts.

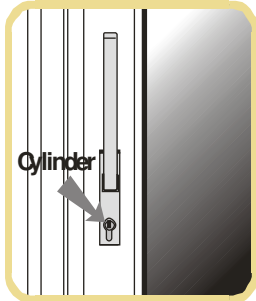

Lock Cylinder

Only lubricate if key entry is difficult.

INLINE SLIDING PATIO DOOR

This heavy duty sliding door may be opened as required to provide ventilation or access.

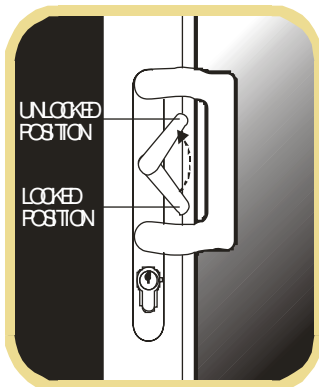

OPERATING INSTRUCTIONS

To Lock

- Slide door to fully closed position.
- Lift lever behind handle. (Bolts and Cams will engage to lock the door.)
- Turn key to fully secure locking mechanism.

To Unlock

- Insert the key in cylinder and rotate to unlock the mechanism.
- Depress lever behind handle. (Bolts and cams will disengage).
- Slide door open

Patio door instructions (continued)

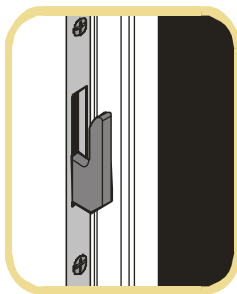
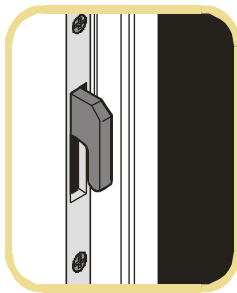

Lubrication - Twice per year & more often in exposed areas.
Oil the locking cams of the mechanism, wipe over the exposed metalwork with a oily cloth.

Lock Cylinder

Only lubricate if key entry is difficult.

Bottom Track

Keep permanently free of dirt and obstruction & lightly oil.